

CARBIDE DISCS



HARDITALIA

your partner in hard metal

OMCD GROUP

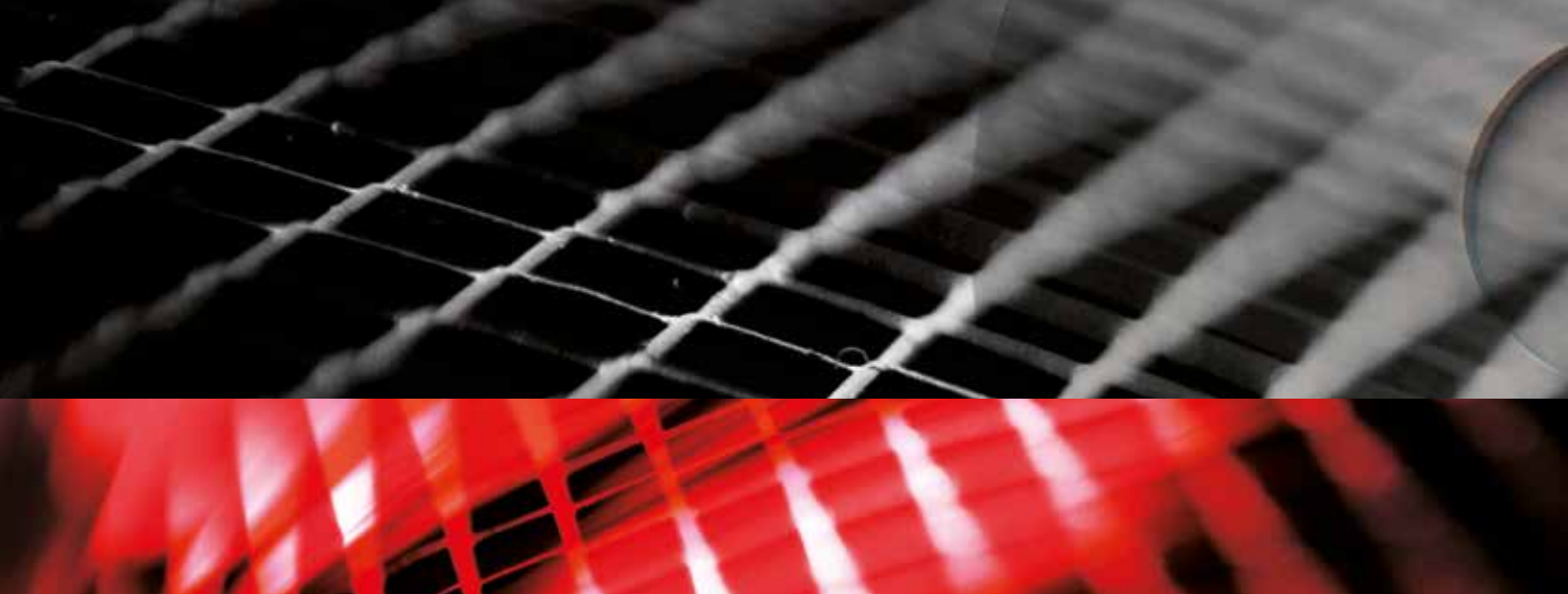

**GET MORE
FASTER.
A FIRST RATE
PRODUCT
IN A VERY
SHORT TIME.**



**BEST QUALITY
IN HARDMETAL ITEMS
JUST IN TIME**

When not in stock we guarantee shipment within three weeks. Shorter delivery, on specific needs, are possible thanks to our flexible manufacturing process.





HARDITALIA

your partner in hard metal

OMCD GROUP

CARBIDE DISCS FOR CIRCULAR KNIVES AND TOOLS

We offer the complete series of hard metal blanks for circular tools and knives, supporting clients with customized solutions, dedicated high performance tungsten carbide grades and fast delivery.



**BLANKS & FACE
GROUND DISCS**



**CUSTOMIZED
PRE-SHAPED DISCS**



**HARD METAL
GRADES**

BLANKS & FACE GROUND DISCS

We manufacture discs in blank condition according to customers' specification. We are able to produce any size in the following ranges:

- outer diameters from 8mm to 308mm
- thickness 0,8mm – 50mm (depending on the outer diameter)

The following chart shows the most common sizes.



outer Ø	inner Ø	Thickness	
		min.	max.
12,6	4,7	0,8	5
	7,7		
15,6	4,7	0,8	5
	7,7		
20,6	4,7	0,8	8
	7,7		
25,6	4,7	0,8	8
	7,7		
30,8	7,7	0,8	8
	9,7		
32,8	7,7	0,8	8
	9,7		
40,8	7,7	0,8	10
	9,7		
	12,5		
50,8	9,7	0,8	10
	12,5		
60,8	9,7	0,8	10
	12,5		
	15,5		
63,8	9,7	0,8	10
	12,5		
	15,5		
71	12,5	0,8	12
	15,5		
	21,5		
76	12,5	0,8	12
	15,5		
	21,5		
81	15,5	0,8	12
	21,5		
	31,5		

outer Ø	inner Ø	Thickness	
		min.	max.
87	21,5	0,9	12
	31,5		
91	21,5	0,9	12
	31,5		
101	21,5	0,9	12
	31,5		
	39,5		
126	21,5	1	15
	31,5		
	39,5		
151	21,5	1	15
	31,5		
	39,5		
161	21,5	1,2	15
	31,5		
	39,5		
181	21,5	1,2	15
	31,5		
	39,5		
201	21,5	1,5	15
	31,5		
	39,5		
251	31,5	1,5	15
	39,5		
256	31,5	1,5	15
	39,5		
283	31,5	1,5	15
	39,5		
308	31,5	1,5	15
	31,5		
	39,5		

CARBIDE DISCS



HARDITALIA

your partner in hard metal

OMCD GROUP

The drawing and charts on this page show the dimensional and geometric tolerances we guarantee for our products.

outer \varnothing	se
12.6 to 32.8	+0.3/-0
40.8 to 60.8	+0.5/-0
63.8 to 91	+0.7/-0
101 to 126	+1/-0
151 to 201	+1.5/-0
251 to 308	+2/-0

outer \varnothing	ss
12.6 to 181	+0.1/-0
201 to 251	+0.2/-0
256 to 308	+0.3/-0

inner \varnothing	si
4.7 to 9.7	+0/-0.1
12.5 to 39.5	+0/-0.2

On demand we supply face ground discs with a ss tolerance of 0.02mm.

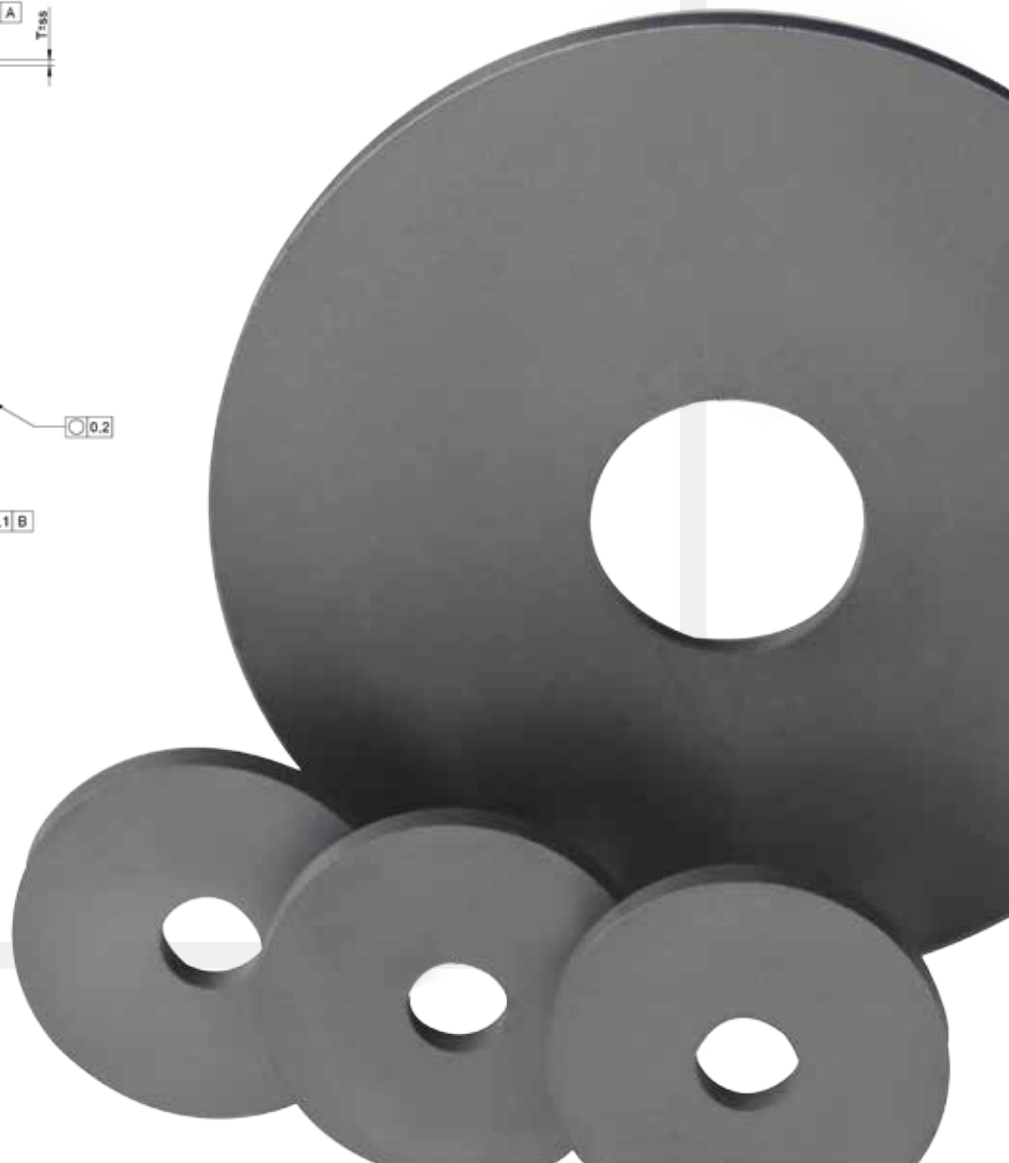
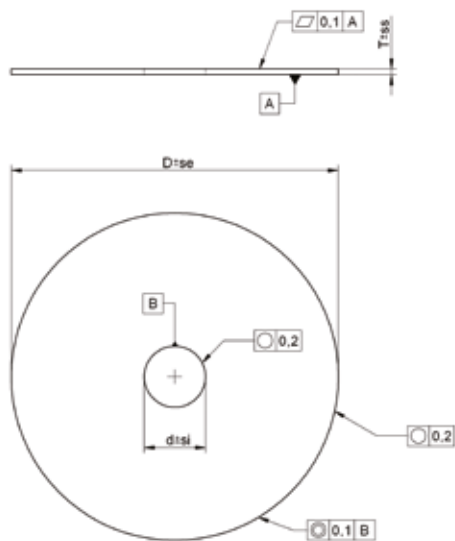

CUSTOMIZED DISCS

Following the customers' needs we manufacture blanks with pre-shaped grooves, drag holes and countersunk bores.

The following drawing shows feasible groove and holes with their relative dimensions for manufacturing.

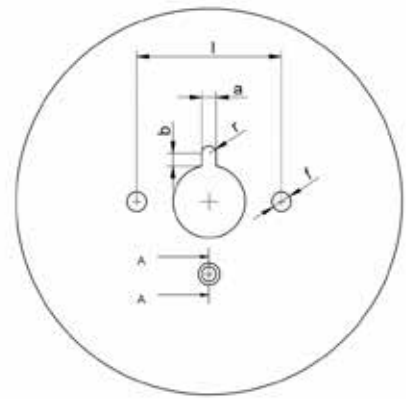



HARD METAL GRADES



H98A

H98A (ISO K03)

Composition	WC + Co
Grain	s
Vickers hardness	1980



J55F

J55F (ISO K20)

Composition	WC + Co
Grain	s-f
Vickers hardness	1550



H78F

H78F (ISO K05)

Composition	WC + Co
Grain	s-f
Vickers hardness	1780



K38B

K38B (ISO K40)

Composition	WC + Co
Grain	f
Vickers hardness	1380

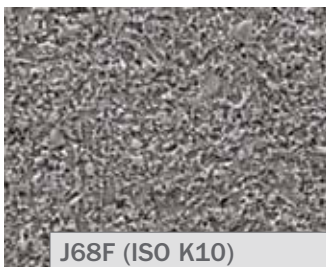

J68F

J68F (ISO K10)

Composition	WC + Co
Grain	s-f
Vickers hardness	1680

IN THE WORLD



Harditalia products are made in Italy and sold all over the world. Thanks to a combined network of direct sales, agents and resellers we can supply our products from Asia to America. A technician is always at the customer's disposal to discuss technical matters and suggest the best solutions.



HARDITALIA

your partner in hard metal

OMCD GROUP

Harditalia srl
 Via Genova 9 - Oggiona con S.Stefano - 21040 (Va) Italia
 Tel. +39 0331 215007 - Fax +39 0331 215024
 harditalia@harditalia.com