

Bar peeling



DIAMIL

tube & bar tools specialists

OMCD GROUP

We manufacture exactly what you need

This is our approach to customers and this is the way we design hard metal parts. Direct contact with our skilled technicians is the way to get it. Discover the value of a special supplier!

A presentation OMDC's Group
TUNED SYNERGY
FOR THE **BEST**

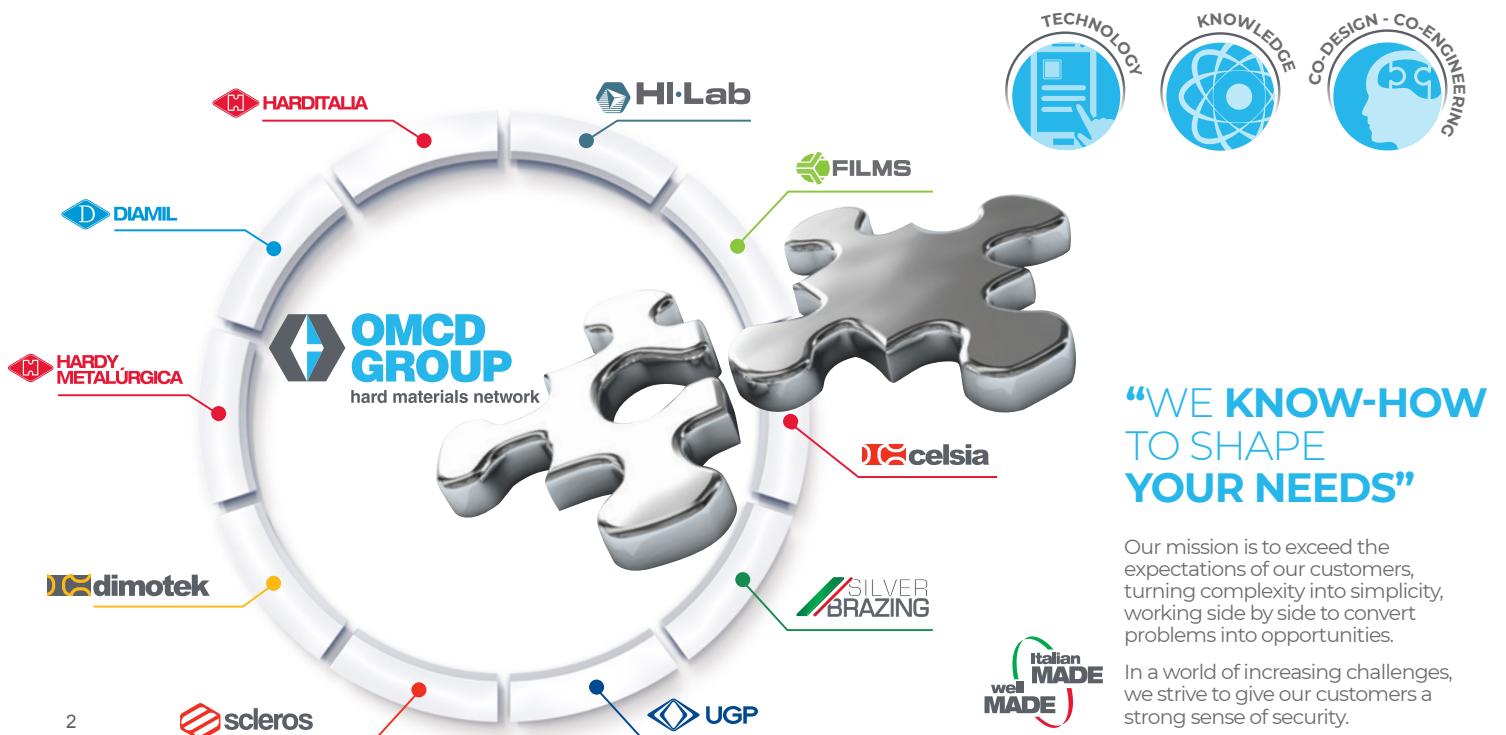



DIAMIL

tube & bar tools specialists



The company

Diamil is the trade mark of OMCD Group, specialized in inserts and tools dedicated to bar and tube industries.

We guarantee full customer's satisfaction with our pre&after sale team offering promptly answer to any customer need. Technical advices to achieve the best productive result, shared know-how, ready on shelf delivery and flexible approach to customer inquiry are the keys of our success.

Being partner of a Group which is a network of dedicated competences in hard material applications we are able to offer a wider range of solutions with products constantly at the top in the market.

Full customer satisfaction is what we look for everyday!





DIAMIL

tube & bar tools specialists



- **Bar peeling inserts**
- **Skiving inserts**
- **Bar peeling toolings**
- **Chamfering inserts and toolings**

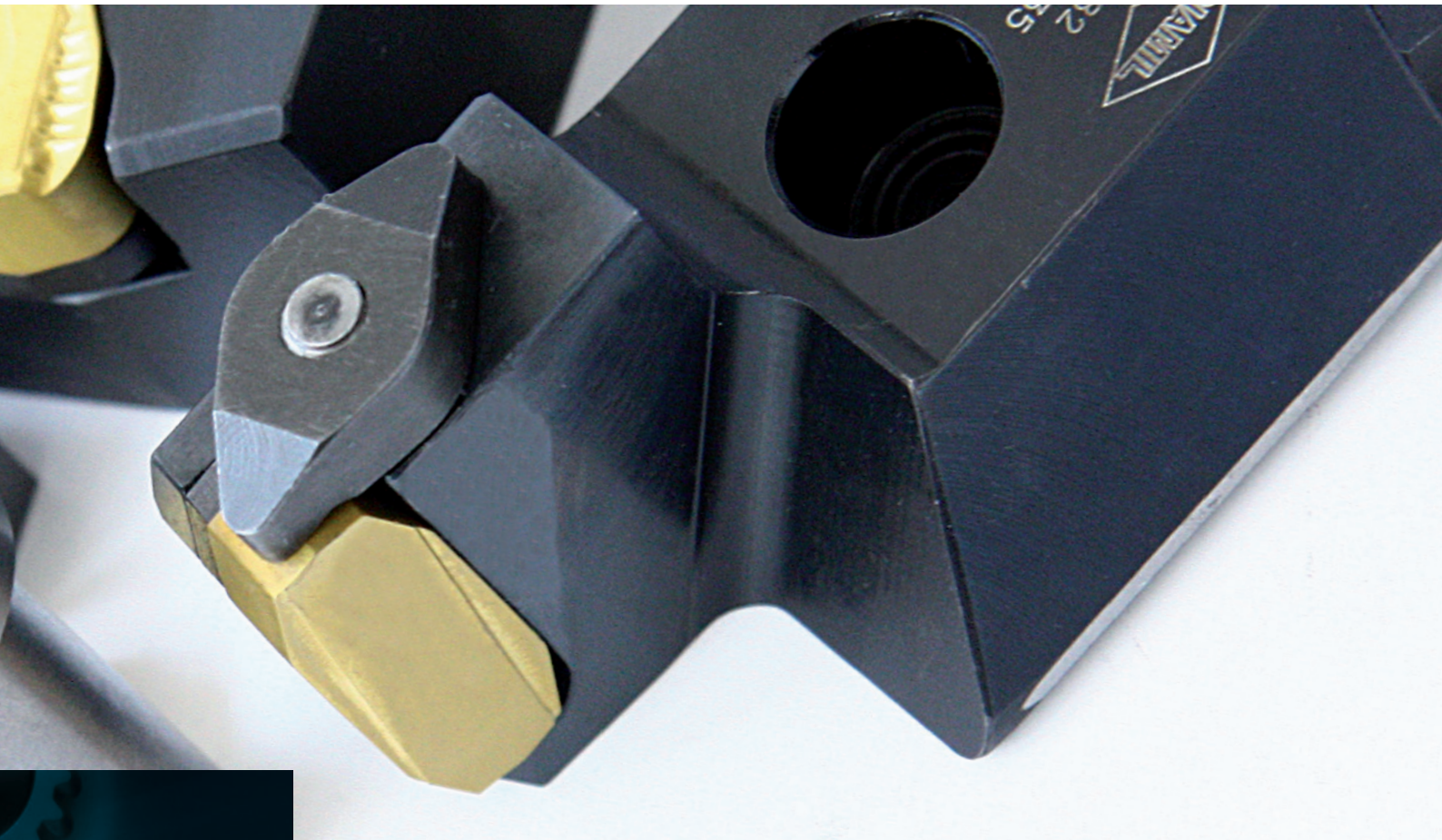

Inserts and toolings

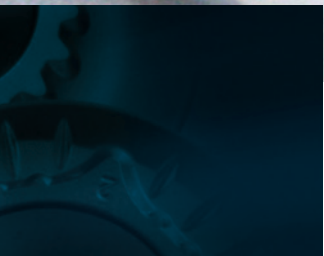

The Diamil's catalogue shows a wide range of inserts designed to optimize the peeling operation whatever the steel, the machine and the coolant used.

The very flexible organisation plus the know-how collected through a continuous monitoring of the market has brought us to better understand our customer needs.

Diamil continuously introduces new grades and new geometries to provide products that can satisfy the more and more challenging demands created by the market in order to achieve the full customers' satisfaction.

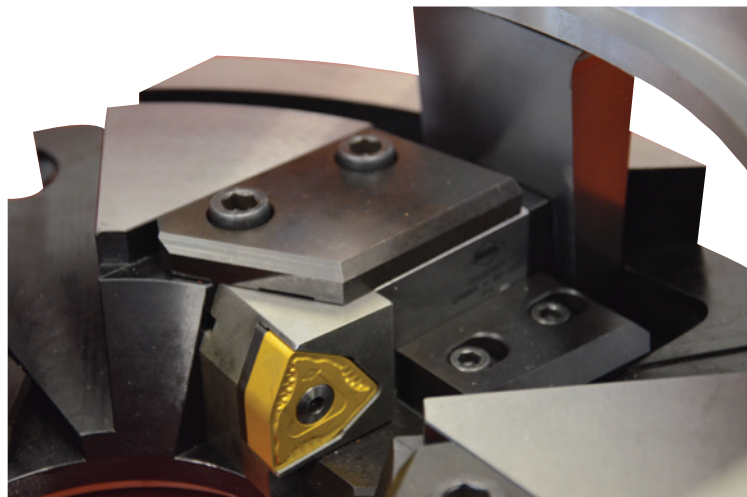



DIAMIL

tube & bar tools specialists



Grade choice according to steel hardness

R kg/mm ²	HB Brinell	HRC Rockwell C	HV Vickers	Diamil grade
52	145		145	D812GPlus
53	148		148	
54	150		150	
55	152		152	
56	154		154	
57	158		158	
58	160		160	
59	162		162	
60	168		168	
61	171		171	
62	177		177	
63	183		183	
64	186		186	
65	189		189	
66	193		193	
67	197		197	
69	201		201	
71	206		206	
73	215		215	
75	220		220	
77	225		225	
79	230		230	
81	235	22	235	

R kg/mm ²	HB Brinell	HRC Rockwell C	HV Vickers	Diamil grade
83	240	23	240	P812GPlus
85	247	24	247	
87	253	25	253	
89	259	26	259	
91	265	27	265	
93	272	28	272	P612GPlus
95	279	29	279	
97	286	30	286	
101	294	31	296	
104	301	32	304	B612GPlus
107	308	33	314	
110	318	34	323	
113	327	35	332	
116	337	36	341	
119	347	37	357	
122	357	38	371	



Our grades

Inserts' grade choice can be made according to several parameters such as steel hardness and composition, bar tips status, machine status, etc.

In the two charts on the side a suggestion is give according to steel composition and hardness. Non the less we strongly suggest to ask to our technicians for the best solution fitting your machining.

Grade	Application
B612GPlus P612GPlus	Austempering steel, martensitic inoxidable steel, duplex, Ti, spring steel, tool steel
P612GPlus P812GPlus	Austenitic inoxidable steel, construction steel, valve steel
D812GPlus	Low carbon steel, Super alloy, duplex



DIAMIL

tube & bar tools specialists

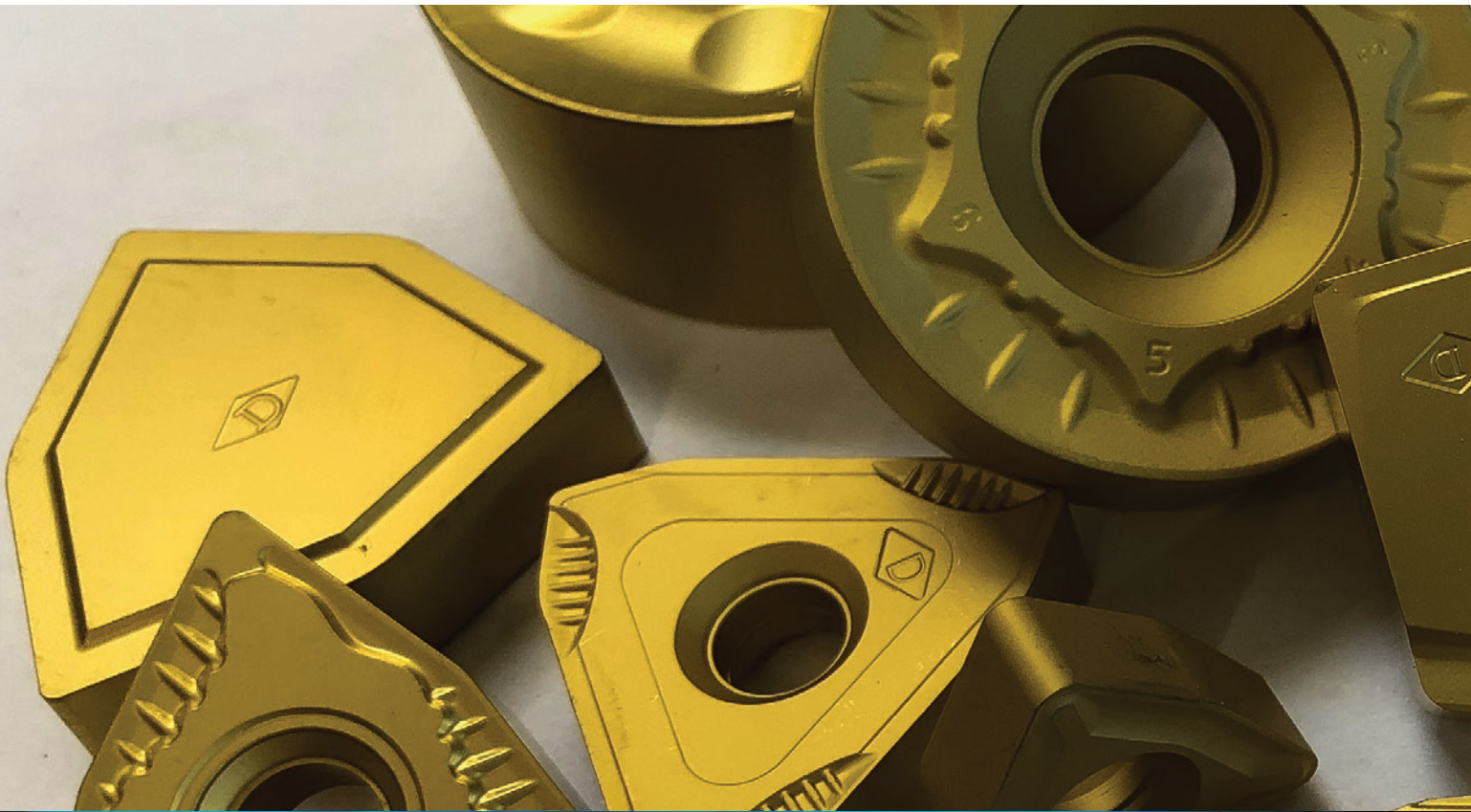

Insert's geometry



Type L e S

Suitable for finishing operations. General purpose geometry for removal up to 3mm on diameter. Available in different lengths to optimize cutting speed and chip flow in peeling head

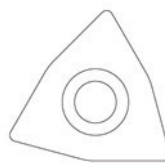

Type W

Suitable for medium rough operations. It has better cutting performance comparing to L and T type when material to remove his higher than 2mm.



Type T

Suitable for finishing operations. Same application as type L but with two additional cutting edges. A good cost saving choice where process is time controlled.

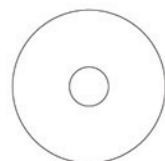



Type R

Suitable for rough operations only. It has to be used in tandem with a finishing insert.

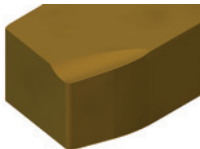

Bar peeling inserts

Chip breaker types:

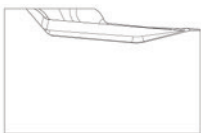
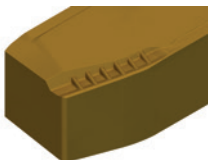
Type	Chipbreaker	Geometry	Description
2H			Classical general purpose chipbreaker
3F			The new generation of general purpose chipbreaker. It's an evolution of type 2H. Offering a better chip control and a reduction in heat generated in cutting.
2F			Innovative chipbreaker with high performance in minimizing chip length. Requires very stable machine and a good coolant flow

Type L

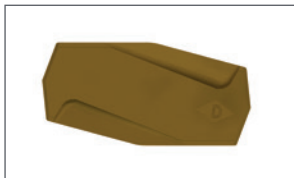
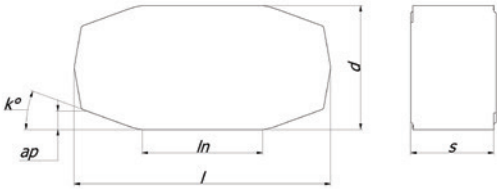

Code	k	ap	ln	T	l	d	s
LNGF 2206-2D	15°	1,5	10	4	22,0	10,00	6,5
LNGF 3107-3D	15°	3,0	14	4	31,0	12,00	7,5
LNGF 3712-2D	15°	3,0	16	4	37,0	17,80	12,0

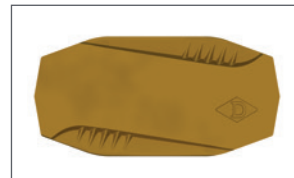

Code	k	ap	ln	T	l	d	s
LNGF 3108-2H	20°	2,0	17	4	31,0	12,0	7,5
LNGF 3712-2H	20°	2,0	18	4	37,0	17,8	12,0
LNGF 3712-3F	20°	2,0	18	4	37,0	18,0	12,0
LNGF 3712-2F	20°	3,0	18	4	37,0	17,8	12,0
LNGF 4312-2H	20°	2,0	26	4	43,2	17,8	12,0

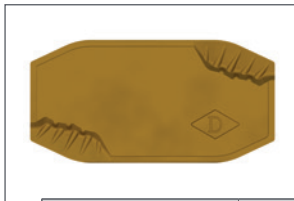

Code	k	ap	ln	T	l	d	s
LNGF 4010-2F	25°	3,5	22	4	40,0	1,0	10,2
LNGF 4010-3F	25°	3,5	22	4	40,0	20,0	10,2
LNGF 4012-2F	25°	3,5	22	4	40,0	20,0	12,2
LNGF 4012-3F	25°	3,5	22	4	40,0	20,0	12,2

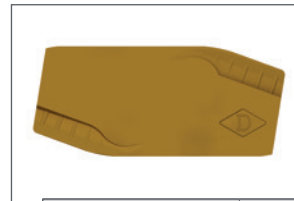

Code	k	ap	ln	T	l	d	s
LNGR 3812-2H	20°	2,5	25	2	38,1	17,46	12,0
LNGR 3812-3F	20°	3,0	25	2	38,1	17,46	12,0
LNGR 3812-2F	20°	3,0	25	2	38,1	17,46	12,0

Type S

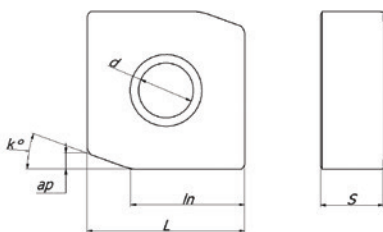

Code	k	ap	ln	T	l	d	s
SNGH 2510-2H	20°	2,0	16,5	2	25	25	10



Type W

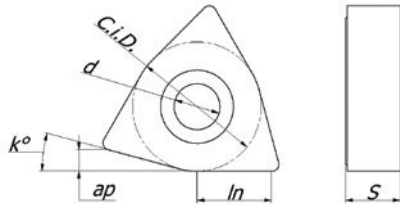

Code	k	ap	T	ln	C.i.D.	d	s
WNGF 2210-3F	25°	4,5	6	10	22,0	-	10
WNGF 3113-3F	25°	5,5	6	17	31,75	-	13,0
WNGF 3114-3F	25°	5,5	6	17	31,75	-	14,0



Code	k	ap	T	ln	C.i.D.	d	s
WNGF 2809-2N	30°	3,0	6	16,9	28,58	-	9,0
WNGF 2809-2F	30°	3,0	6	16,9	28,58	-	9,0

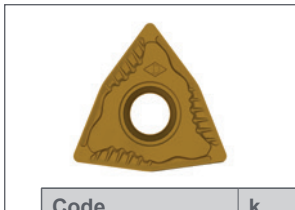

Code	k	ap	T	ln	C.i.D.	d	s
WNGJ 1106-2H	15°	1,5	6	8	15,88	6,4	6,5
WNGJ 2209-2H	15°	3,0	6	10	22,22	8,0	9,5
WNGJ 2209-2F	15°	3,0	6	10	22,22	8,0	9,5

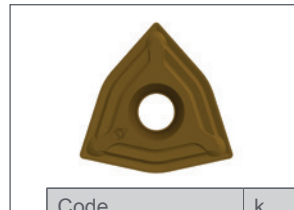

Code	k	ap	T	ln	C.i.D.	d	s
WNGJ 1806-2H	24°	2,0	6	11,2	18,00	5,4	6,4



Code	k	ap	T	ln	C.i.D.	d	s
WNGJ 3113-3F	25°	5,5	6	17	31,75	9,0	13,0
WNGJ 3114-3F	25°	5,5	6	17	31,75	9,0	14,0



Code	k	ap	T	ln	C.i.D.	d	s
WNGJ 0804-2N	20°	1,0	6	7,7	12,70	5,2	4,8

Type T

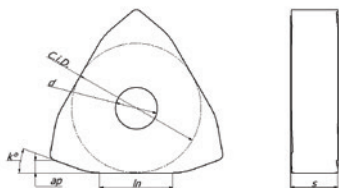

Code	k	ap	T	ln	C.i.D.	d	s
TNGJ 2208-2H	20°	1,5	6	16	22,0	7,0	8,0
TNGJ 2208-3F	20°	1,5	6	16	22,0	7,0	8,0
TNGJ 2810-2H	20°	2,5	6	20	28,5	7,0	10,0
TNGJ 2810-3F	20°	3,0	6	20	28,5	7,0	10,0

Type R

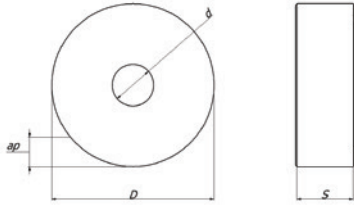

Code	ap	D	d	s
RNMJ 2509-2H	3,0	25,4	9,12	9,5



Code	ap	D	d	s
RNGH 3812-3F	7,5	38,1	12,8	12,7

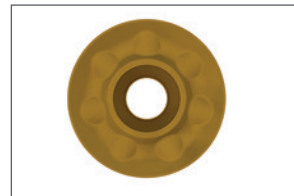

Code	ap	D	d	s
RNGH 5018-2F	5,0	50,0	12,8	18,0



Code	ap	D	d	s
RNGH 5018-2H	9,0	50,0	12,8	18,0



Code	ap	D	d	s
RCMT 3209	1,5	32,0	9,12	9,5

Skiving inserts

Diamil is offering the two types of skiving inserts: the one used in clamping tools and the one used in screw fixed tools.

In order to cover all the internal skiving operations at the best, Diamil is now offering a combination of different chipbreakers and sizes

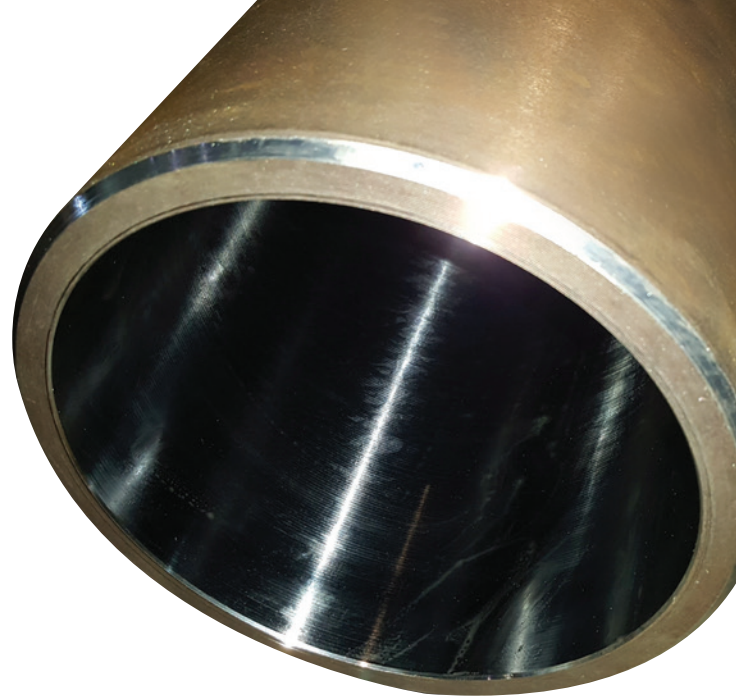

Inserts for clamping tools

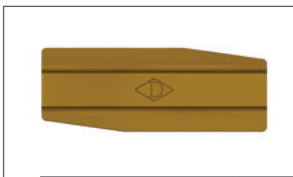

Code	k	ap	In	T	l	d	s
LNGF 1503-2E	8°	0,3	9,4	2	14,9	5,50	3,5

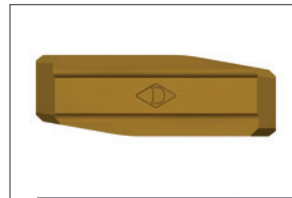

Code	k	ap	In	T	l	d	s
LNGF 1505-2E	10°	0,3	7,7	2	14,9	5,00	5,0

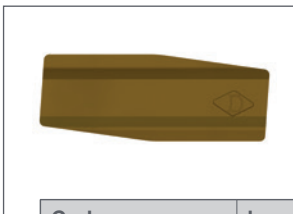

Code	k	ap	In	T	l	d	s
LNGF 2006-2E	8°	0,8	9,5	4	20,4	8,00	6,0
LNGF 2006-2F	8°	0,6	9,8	4	20,5	7,98	6,0
LNMF 2506-2E	8°	1,0	11,5	4	25,4	10,00	6,0

Inserts for screw fixed tools



Code	k	ap	In	T	l	d	s
LNGX 1002-2N	7°	0,3	6	2	10,0	7,50	2,4



Code	k	ap	In	T	l	d	s
LNGX 12T3-2H	8°	0,5	11,1	2	12,0	8,00	4,0
LNGX 1704-2H	8°	0,7	16	2	17,0	12,00	4,8

Bar peeling toolings

Diamil is currently designing and manufacturing toolings and carbide spare parts for all the peeling machines.

Whether the customer is interested in spare parts only or in a new project to improve machine performance we are able to fulfill its needs.

We design, manufacture and develop peeling head, both single and tandem insert's and antiwear parts to be used in the bar guiding system. The wide range of inserts in our peeling program and the wide experience developed in the past 20 years allows us to find the best solution for every machine and type of machining.

In order to facilitate data collection we created the following chart and relative drawings with the main dimensions needed to quote a tools and create a draft for an alternative solution.

Parameter	Description
L	Head Total Height
L1	Centering Gap
α	Fixing Plug Angle
$\varnothing A$	Inner Diameter
$\varnothing B$	Centering Diameter
$\varnothing C$	Fixing Diameter
$\varnothing D$	External Diameter

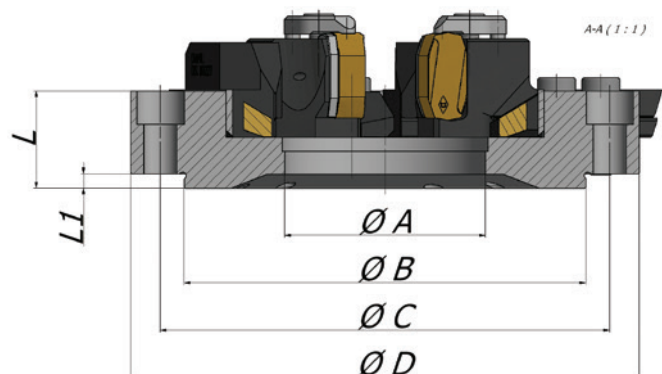
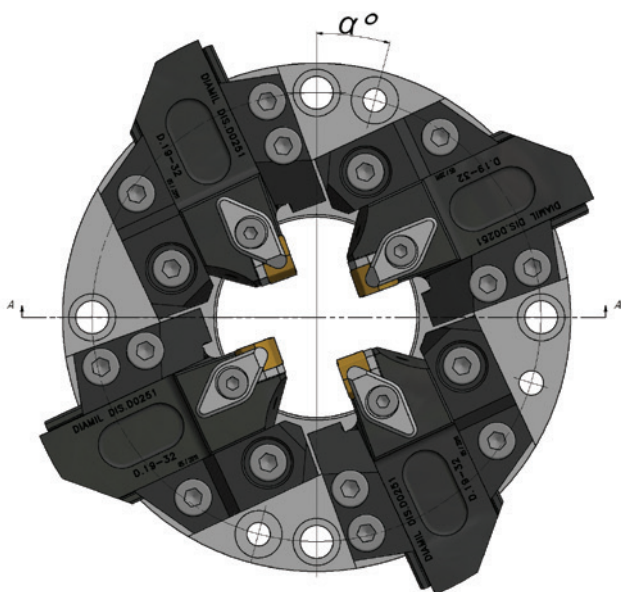

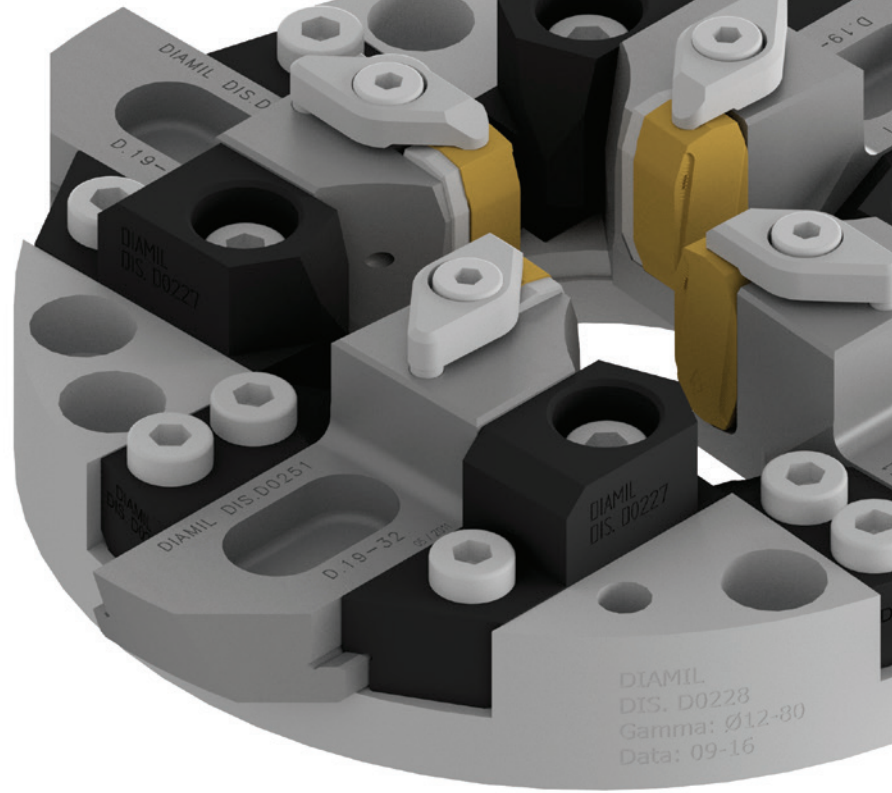

Parameter	Description
L	Total Length
H	Cutting Edge Height
H1	Total Height
A	Insert Seat Shoulder
B	Total Width

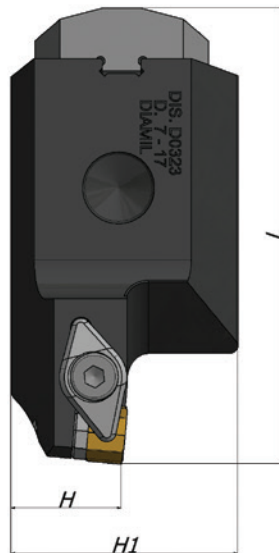
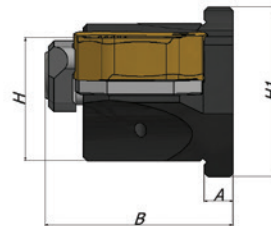
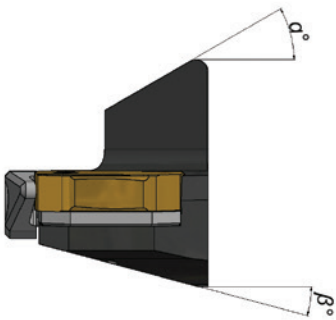

Chamfering Inserts

Inserts for turning

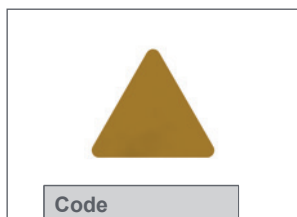

Code

TPUN 160308

TPUN 220412

TPUN 270616

TPUN 330613

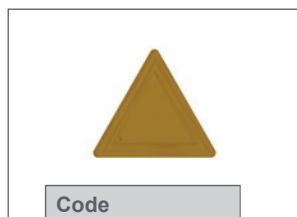

Code

TPMR 160308

TPMR 220408

TPMR 270616

Inserts for milling

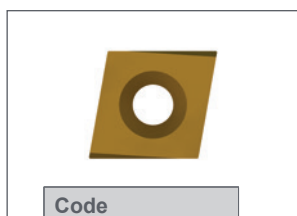

Code

CNCQ 150604



Code

SPCT 1504-AP-5A



Formulas for bar peeling

Cutting speed [m/min]

$$V_c = \frac{d_1 * \pi * n}{1000}$$

Revolutions of spindle [rev/min]

$$n = \frac{v_c * 1000}{d_1 * \pi}$$

Through feed speed [m/min]

$$v_f = f * n$$

Feed [mm/rev.]

$$f = \frac{V_f}{n}$$

Chip removal rate [cm³ / min]

$$Q = a_p * f * v_c$$

Steel designation comparison chart

W-Nr.	DIN	UNI	AISI/SAE	Cutting speed Vc= m/min Reduction of diameter up to 2mm	Advanced per round mm	Material Group
Constructional steel						
1.0401	C15	C15C16	1015	110 – 180	5 – 20	
1.0402	C22	C20C21	1020			
1.0501	C35	C35	1035			
1.0503	C45	C45	1045			
1.0535	C55	C55	1055			
1.0601	C60	C60	1060			
1.0715	9SMn28	CF9SMn28	1213			
1.0718	9SMnPb28	CF9SMnPb28	12L13			
1.0722	10SPb20	CF10SPb20	-			
1.0726	35S20	-	1140			
1.0736	9SMn36	CF9SMn36	1215			
1.0737	9SMnPb36	CF9SMnPb36	12L14			
1.0904	55Si7	55Si8	9255			
1.0961	60SiCr7	60SiCr8	9262			
1.1141	Ck15	C16	1015			
1.1157	40Mn4	-	1039			
1.1158	Ck25	-	1025			
1.1167	36Mn5	-	1335			
1.1170	28Mn6	C28Mn	1330			
1.1183	Cf35	C36	1035			
1.1191	Ck45	C45	1045			
1.1203	Ck55	C50	1055			
1.1213	Cf53	C53	1050			
1.1221	Ck60	C60	1060			
1.1274	Ck101	-	1095			
1.3401	X120Mn12	XG120Mn12	-	90 – 140	5 – 15	P
1.3505	100Cr6	100Cr6	52100			
1.5415	16Mo3	16Mo3KW	ASTM A204Gr.A			
1.5423	16Mo5	16Mo5	4520			
1.5622	14Ni6	14Ni6	ASTM A350LF5			
1.5662	X8Ni9	X10Ni9	ASTM A353			
1.5680	12Ni19	-	2515			
1.5710	36NiCr6	-	3135			
1.5732	14NiCr10	16NiCr11	3415			
1.5752	14NiCr14	-	3415;3310			
1.6511	36CrNiMo4	38NiCrMo4(KB)	9840	80 – 120	4 – 14	
1.6523	21NiCrMo2	20NiCrMo2	8620			
1.6546	40NiCrMo22	40NiCrMo2(KB)	8740			
1.6582	34CrNiMo6	35NiCrMo6(KB)	4340			
1.6587	17CrNiMo6	-	-			
1.6657	14NiCrMo134	15NiCrMo13	-			
1.7015	15Cr3	-	5015			
1.7033	34Cr4	34Cr4(KB)	5132			
1.7035	41Cr4	41Cr4	5140			
1.7045	42Cr4	-	5140			
1.7131	16MnCr5	16MnCr5	5115			
1.7176	55Cr3	-	5155			
1.7218	25CrMo4	25CrMo4(KB)	4130			
1.7220	34CrMo4	35CrMo4	4137;4135			
1.7223	41CrMo4	41CrMo4	4140;4142			
1.7225	42CrMo4	42CrMo4	4140			
1.7262	15CrMo5	-	-			
1.7335	13CrMo4 4	14CrMo4 5	ASTM A182 F11;F12			
1.7361	32CrMo12	32CrMo12	-			
1.7380	10CrMo9, 10	12CrMo9,10	ASTM A182 F.22			
1.7715	14MoV6 3	-	-			
1.8159	50CrV4	50CrV4	6150			
1.8509	41CrAlMo7	41CrAlMo7	-			
1.8523	39CrMoV13 9	36CrMoV12	-			

The **OMCD Group** headed by the Tedeschi family for two generations, is a multinational company made up of **10 brands active in the field of Hard Metal, sintered copper/tungsten and precious metals.**

Its centralized structure and **synergy between each brand** guarantees **control of the entire production process**, from the refining of minerals to the micro-finishing operations.

Technical **competence**, continuous **innovation** and focus on **customer satisfaction** are just some of the reasons why every day more and more companies rely on OMCD Group as their commercial business partner.



DOWNLOAD
the digital version



Rev. 06/2022



DIAMIL
tube & bar tools specialists
OMCD GROUP

Diamil by Harditalia srl
Via Genova 9
Oggiona con S.Stefano - 21040 (Va) Italia
Tel. +39 0331 215007 - Fax +39 0331 215024
harditalia@harditalia.com
diamil.it / harditalia.com