

# Bar peeling



**DIAMIL**

tube & bar tools specialists

**OMCD GROUP**



# The Italian brand

of tube & bar tools specialists

The added value of DIAMIL is that the people in charge of the design and the production of inserts **know firsthand** any problem and each aspect related to the **bar peeling**: from the selection of the insert and related equipment needed for peeling and beveling, to spare parts such as pins and rollers of the infeed and outfeed guides, to the optimization of machine parameters to achieve the best possible result.

The know-how and experience of such a competent staff allow to create **products and solutions in line with the real needs** of the market, both for standard and customized items.





# Bar peeling

After forging and rolling, the resulting bars (or coil) need a turning operation to **remove surface defects and achieve accurate dimensions.**

A peeling machine is a special multi insert lathe, capable of performing this operation continuously and efficiently, achieving very tight dimensional tolerances and very low surface roughness.

*We are what we repeatedly do.  
Therefore, excellence is not an action, but a habit.*

*Aristotele*

# HOW TO CHOOSE

## How to choose the tool

The main factors to be considered when choosing the proper tools for bar peeling are:

- characteristics of the peeling machine and the working conditions of its parts;
- geometric quality and dimensions of the raw bar;
- finishing characteristics of the peeled bar;
- mechanical properties and chemical composition of the material to be processed.

The tool consists of two parts  
the insert cartridge and the insert itself.



## How to choose the right insert cartridge

Key elements in choosing the insert cartridge are:

- range of diameters to be processed
- expected average stock removal
- material to be processed

The choice of the insert cartridge is usually made at the time of purchasing the peeling machine and determines the type of inserts that can be used. The insert changes are limited as they have to comply with the limits imposed by the peeling head and the positions of the entry and exit guides. In most cases, it is possible to change the shape of the insert or the clamping system, while the changes of the peeling head often requires to newly create all the tooling connected to it.

When purchasing a new machine, it is therefore necessary to carefully evaluate the range of diameters to be covered, which of these diameters have the highest consumption rates, the type of material to be peeled and, based on this information, choose the shape of the cartridge to be used.

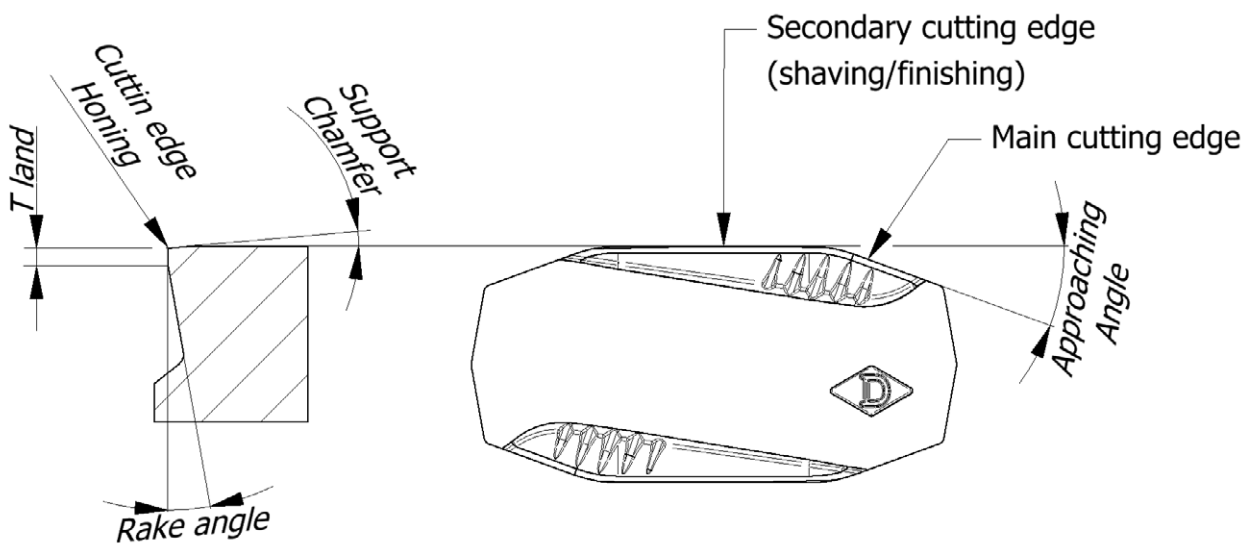

## How to choose the insert

Key elements in choosing the most suitable inserts for the processing are:

### 1. Expected average stock removal

The amount of material to be removed determines the shape and number of inserts working simultaneously, their thickness and size, which will increase depending on the material to be removed.

- Stock removal between 0.5 and 2 mm on the radius can be handled with a single insert.
- Stock removal between 2 and 5 mm on the radius requires two inserts per cartridge: a roughing insert, which removes the bulk of the material and usually has a round shape, and a finishing insert, typically parallelepiped in shape. Combinations of trigons can also be used depending on the composition of the bars to be peeled.
- Greater stock removal typically requires an average of three inserts: two roughing inserts, usually with a round or triangular shape, and a finishing insert, which is almost always rhomboidal.

### 2. Desired finishing grade

The finishing grade of a bar depends on the cutting parameters, the geometry of the chip-breaker, the length of the scraping part, and the sharpness of the cutting edge. The length of the scraping part and the type of chip-breaker are essential elements. In general, the longer the scraping part, the better the finishing (this relationship is not valid for materials with high elastic behavior or a particular tendency to stick), while chip management is fundamental not only to keep consumption low and the cutting area clean, but also to avoid leaving marks in this area.

### 3. Type of material to be processed

The type of material to be processed influences the insert geometry, the chip-breaker, and the grade of Hard Metal. The correct choice is a balance of various critical factors and usually requires the opinion of an expert technician.

#### Choosing the grade of Hard Metal

Choosing the correct grade of Hard Metal involves balancing wear resistance and impact resistance needs.

Below is a summary table of the grades to be used according to the material hardness.

However, this should be taken only as a rough indication, as other data needs to be associated to accurately identify the correct grade:

Grade	Features	ISO Range	Steel hardness Range
D812G	Grade with high toughness, able to withstand the heaviest applications. The grain size and composition have been specifically designed to reduce the risk of chipping and breakage to almost zero.	M30-M45 P30-P45	HB <200 HV <210 Kg/mm <sup>2</sup> <68
X812G	<b>NEW GRADE!</b> <b>Evolution of grade D812G. It retains its properties, with the addition of greater wear resistance, consequently increasing the service life of the insert.</b>	M30-M45 P30-P45	HB <220 HV <230 Kg/mm <sup>2</sup> <75
P812G	Very versatile grade that can be used for a wide variety of applications. Balance wear resistance and toughness very well, achieving excellent performance with most materials.	M25-M35 P25-P35	HB 200→270 HV 210→285 Kg/mm <sup>2</sup> 68→91
X612G	<b>NEW GRADE!</b> <b>The link between grades P612G and P812G. It combines the best of both, achieving a perfect marriage of hardness and strength.</b>	M20-M30 P20-P30	HB 220→280 HV 230→295 Kg/mm <sup>2</sup> 75→95
P612G	A grade with high wear resistance. Recommended for steel with high hardness or containing very abrasive elements. Also gives excellent performance in machining Duplex and Titanium.	M15-M25 P15-P25	HB 260→300 HV 275→315 Kg/mm <sup>2</sup> 90→105
B612G	The hardest grade in the range. It takes wear resistance to the maximum, giving the insert a long life even under extreme conditions. Great with tool steel, spring steel, or Titanium, but cutting conditions must be perfect to avoid chipping.	M05-M15 P05-P15	HB >300 HV >315 Kg/mm <sup>2</sup> >105







## Choosing the chip-breaker

When choosing the chip-breaker, it is important to consider the chemical composition and heat treatments undergone by the bar, as they influence chip behavior. Generally, low-alloy and not treated steels are easier to control the chip. As material hardness increases, often associated with heat treatments, there is an improvement in chip control in the range between 250 and 300HB, followed by higher hardness values.

Alloying elements that enhance the elastic behavior of the material, such as Ni and Ti, usually make chip management more difficult. This is because the chip tends to behave in a “super-elastic” manner, not reaching rupture due to plastic deformation but curling up on itself to form a “spring”.

Highly abrasive elements, such as Cr, W, and Si, have a secondary effect on the chip management, as they tend to quickly wear out the active parts of the chip-breaker, reducing its effectiveness.

Very soft materials, such as those containing Pb or S, usually have more cutting and sticking problems than chip problems. In this case, it is not so much the role of the chip-breaker, but the sharpness of the cutting edge that plays a crucial role in the quality of the finished surface.

TYPE	CHIPBREAKER	GEOMETRY	DESCRIPTION
2H			Classical general purpose chipbreaker
3F			The new generation of general purpose chipbreaker. It's an evolution of type 2H. Offering a better chip control and a reduction in heat generated in cutting.
2F			Innovative chipbreaker with high performance in minimizing chip length. Requires very stable machine and a good coolant flow

Another element not to be overlooked in choosing the chip-breaker is the average stock removal achieved. Chip-breakers are usually set to work halfway through the suggested removal range for the specific insert. If working continuously with removals at the limits of the characteristic range, an accurate choice has to be made, taking into account the chip section and the cutting force necessary to generate it.

The side support phase is also dependent on the hardness of the material to be peeled. This phase can vary in angle (depending on the angle of the inclination of the tool) and in size and serves to create a zone with neutral inclination with respect to the bar capable of increasing the pressure applied to the bar itself (stabilizing it) and improving the “shaving” action of the secondary cutting edge, thus increasing the surface quality. It can be said that the size of the phase is inversely proportional to the hardness of the steel, although it is not an exact rule as some special situations may require extremely exaggerated support phases on one side or the other to improve other aspects of the peeling process.

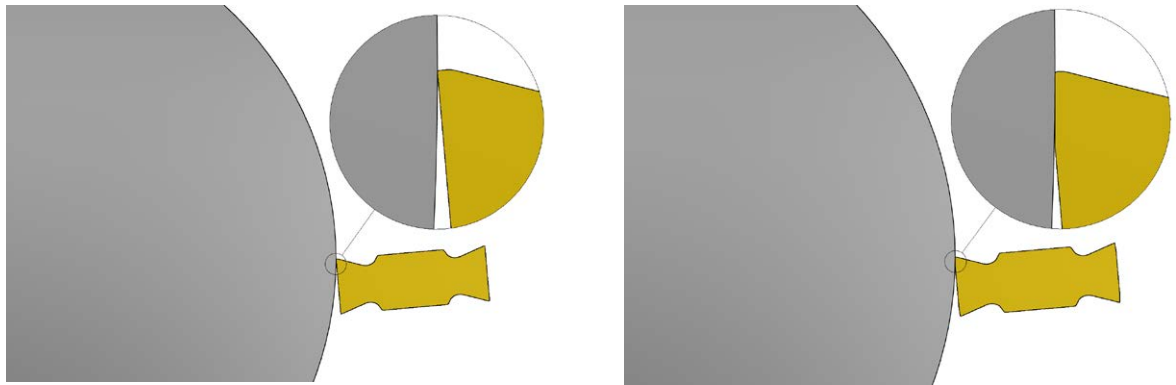
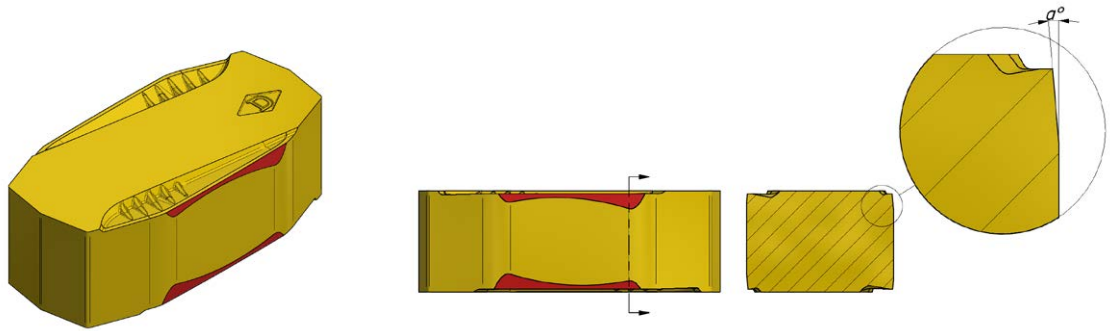

#### 4. Range of diameters to be processed

- For diameters from 8 to 20 mm, it is important to have inserts of small dimensions, low thickness, and screw or lateral fixing, keeping them close to the entry guides to reduce the possibility of vibration on entry and exit. This will facilitate chip evacuation and avoid excessive torsional load on the bar.
- For diameters from 20 to 40 mm, it is usually important to optimize the length of the cutting edge based on processing parameters, which in turn depend on the composition of the bar.
- For diameters from 40 to 60 mm, it is important to consider the stock removal in order to choose an insert capable of supporting the cutting force. This aspect becomes even more important in the range of 60-100 where it is also necessary to carefully choose the insert shape by balancing the cutting angle and length of the cutting edge.

For large-diameter bars, especially those from 100mm upwards, the range of diameters to be processed is often associated with the amount of material to be removed.

#### 5. Cutting edge efficiency status

Improperly maintained systems or problems concerning the guide system as well as the loading and unloading of bars often lead to vibrations during the cutting and the possibility of uneven loads on the inserts. In these cases, when choosing the insert, it is necessary to balance the machine's inefficiency with inserts capable of withstanding extra loads, more resistant to impacts and vibrations.



# Formulas for bar peeling

Cutting speed [m/min]

$$V_c = \frac{d_1 * \pi * n}{1000}$$

Revolutions of spindle [rev/min]

$$n = \frac{v_c * 1000}{d_1 * \pi}$$

Through feed speed [m/min]

$$v_f = f * n$$

Feed [mm/rev.]

$$f = \frac{V_f}{n}$$

Chip removal rate [cm<sup>3</sup> / min]

$$Q = a_p * f * v_c$$

# External Peeling

The choice of peeling insert is very important, and even small differences can affect the final result.

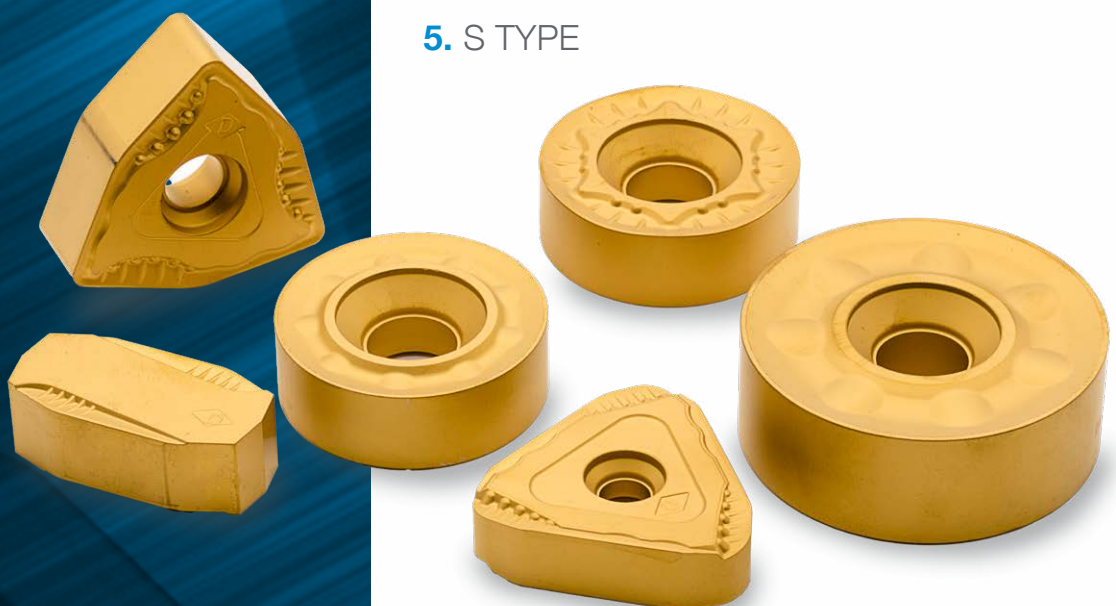

For this reason, the Diamil range includes several shapes, sizes and grades so as to cover every need.

1. L TYPE
2. R TYPE
3. W TYPE
4. T TYPE
5. S TYPE







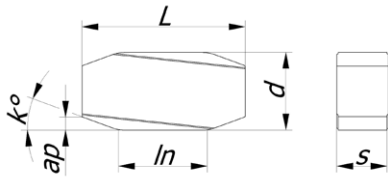

External Peeling

# L Type | External Peeling



	CODE	T	$k^\circ$	ap	ln	L	d	s
	LNGF 4010 - 2F	4	25°	3,5	22	40,0	20,0	10,2
	LNGF 4010 - 3F	4	25°	3,5	22	40,0	20,0	10,2
	LNGF 4012 - 3F	4	25°	3,5	22	40,0	20,0	12,2



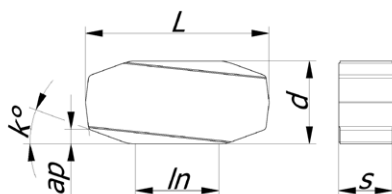



	CODE	T	$k^\circ$	ap	ln	L	d	s
	LNGF 3107 - 2F	4	20°	2,0	17	31,0	12,0	7,5
	LNGF 3108 - 2H	4	20°	2,0	17	31,0	12,0	7,5
	LNGF 3712 - 2F	4	20°	2,0	18	37,0	17,8	12,0
	LNGF 3712 - 2H	4	20°	2,0	18	37,0	17,8	12,0
	LNGF 3712 - 3F	4	20°	2,0	18	37,0	18,0	12,0
	LNGF 4312 - 2H	4	20°	2,0	26	43,2	17,8	12,0

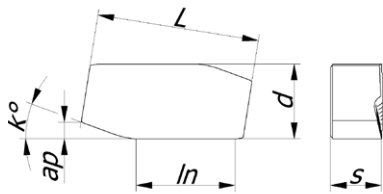

# L Type | External Peeling

	CODE	T	$k^\circ$	ap	ln	L	d	s
	LNGR 3812 - 2F	2	20°	3,0	25	38,1	17,46	12,0
	LNGR 3812 - 3F	2	20°	3,0	25	38,1	17,46	12,0
	LNGR 3812 - 2H	2	20°	2,5	25	38,1	17,46	12,0



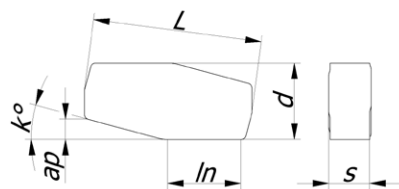

	CODE	T	$k^\circ$	ap	ln	L	d	s
	LNGF 2206 - 2D	4	15°	1,5	10	22,0	10,00	6,5
	LNGF 3107 - 3D	4	15°	3,0	14	31,0	12,00	7,5
	LNGF 3712 - 2D	4	15°	3,0	16	37,0	17,80	12,0



# R Type | External Peeling

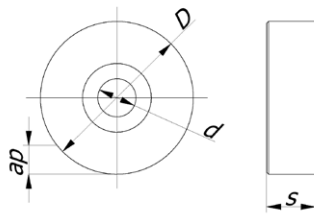





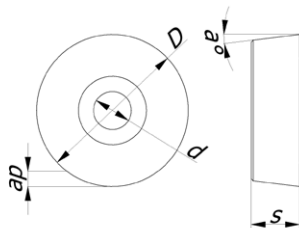



	CODE	ap	D	d	s
	RNGH 3812-2F	7,5	38,1	12,8	12,7
	RNGH 3812-3F	7,5	38,1	12,8	12,7
	RNGH 5018-2F	5,0	50,0	12,8	18,0
	RNGH 5018-2H	9,0	50,0	12,8	18,0
	RNMJ 2509-2H	3,0	25,4	9,12	9,5



	CODE	ap	D	d	s
	RCMT 3209MO	1,5	32,0	9,12	9,5



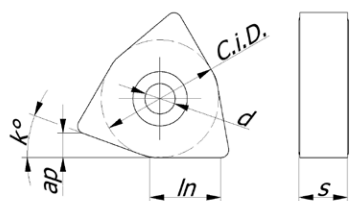

# W Type | External Peeling

	CODE	T	k°	ap	ln	L	d	s
	WNGF 2210-3F	6	25°	4,5	10	22,0	-	10
	WNGF 2809-2F	6	30°	3,0	16,9	28,58	-	9,0
	WNGF 2809-2N	6	30°	3,0	16,9	28,58	-	9,0
	WNGF 3113-3F	6	25°	5,5	17	31,75	-	13,0
	WNGF 3114-3F	6	25°	5,5	17	31,75	-	14,0
	WNGJ 1106-2H	6	15°	1,5	8	15,88	6,4	6,5
	WNGJ 1806-2H	6	24°	2,0	11,2	18,00	5,4	6,4
	WNGJ 2209-2F	6	15°	3,0	10	22,22	8,0	9,5
	WNGJ 2209-2H	6	15°	3,0	10	22,22	8,0	9,5
	WNGJ 3113-3F	6	25°	5,5	17	31,75	9,0	13,0
	WNGJ 3114-3F	6	25°	5,5	17	31,75	9,0	14,0
	WNMU 0804-2N	6	20°	1,0	7,7	12,70	5,2	4,8

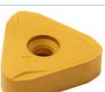

# T Type | External Peeling

	CODE	T	k°	ap	ln	L	d	s
	TNGJ 1806-2H	6	20°	1,0	16,6	18,00	5,5	6,35
	TNGJ 2208-3F	6	20°	1,5	16	22,0	7,0	8,0
	TNGJ 2208-2H	6	20°	1,5	16	22,0	7,0	8,0
	TNGJ 2810-3F	6	20°	3,0	20	28,5	7,0	10,0
	TNGJ 2810-2H	6	20°	3,0	20	28,5	7,0	10,0

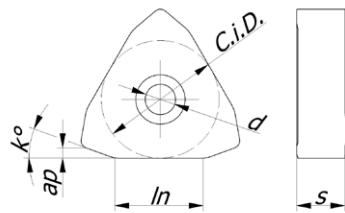

# S Type | External Peeling

	CODE	T	k°	ap	ln	L	d	s
	SNGH 2510-2H	2	20°	2,0	16,5	25	8,7	10

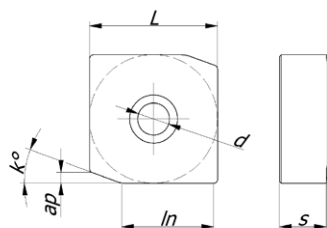

# Skiving Insert

To calibrate and finish seamless pipes, an “internal peeling” operation is required.

Diamil is offering two types of skiving inserts: the one used in clamping tools and the one used in screw fixed tools.

1. Inserts for screw fixed tools
2. Inserts for clamping tools

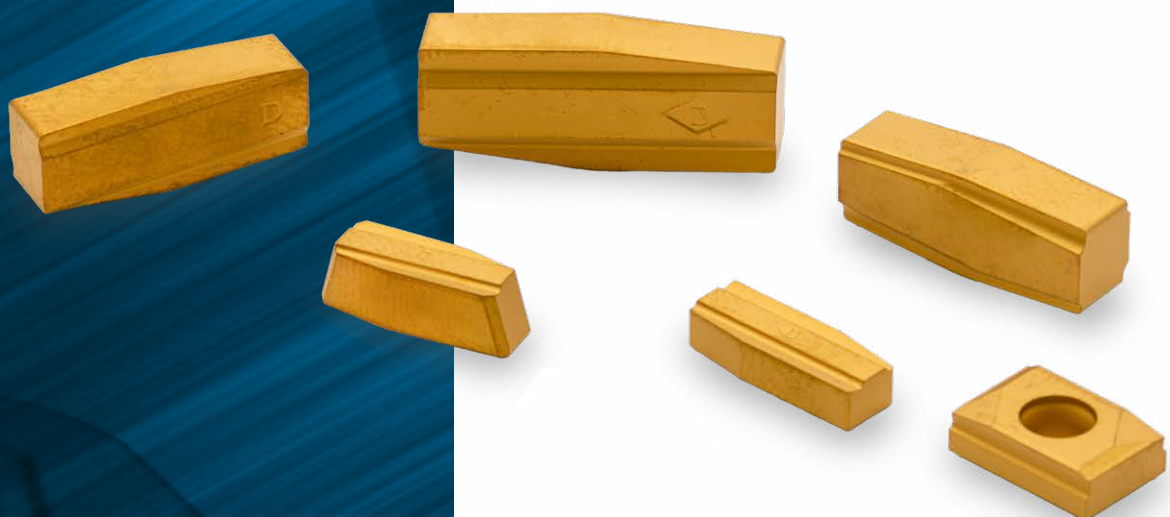

Skiving Insert



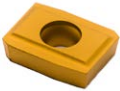
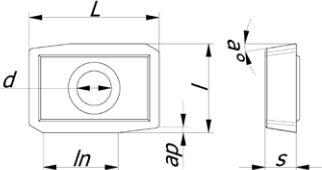

## Inserts for screw fixed tools

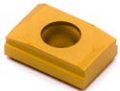
	CODE	T	$a^\circ$	$ap$	$ln$	L	l	d	s
	LNGX 1002-2N	2	$9^\circ$	0,3	6	10,0	7,50	3	2,4
									

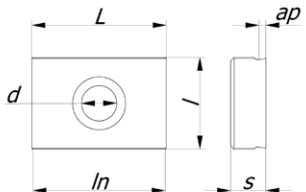
	CODE	T	$ap$	$ln$	L	l	d	s	
	LNGX 12T3-2H	2	0,5	11,1	12,0	8,00	3,7	4,0	
	LNGX 1704-2H	2	0,7	16	17,0	12,00	4,3	4,8	
									

## Inserts for clamping tools

	CODE	T	$k^\circ$	$ap$	$ln$	L	d	s	
	LNGF 1503-2E	2	$8^\circ$	0,3	9,4	14,9	5,50	3,5	
	LNGF 1505-2E	2	$10^\circ$	0,3	7,7	14,9	5,00	5,0	
	LNGF 2006-2E	4	$8^\circ$	0,4	9,5	20,4	8,00	6,0	
	LNGF 2006-2F	4	$8^\circ$	0,4	9,8	20,5	7,98	6,0	
	LNGF 2006-2H	4	$8^\circ$	0,4	9,8	20,5	7,98	6,0	
	LNGF 2506-2E	4	$8^\circ$	0,6	11,5	25,4	10,00	6,0	
									

# Chamfering



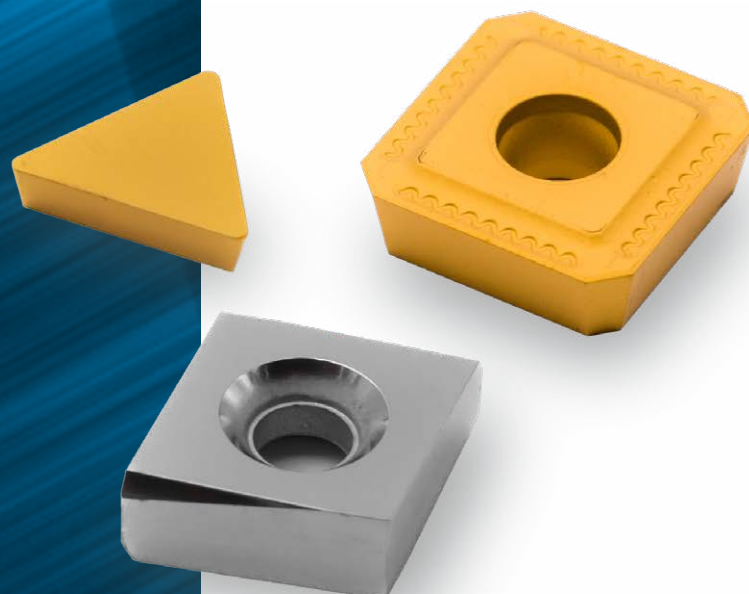

To reduce stress on peeling inserts, or sometimes just to conform to the market standard, bar ends can be beveled.

This can be done by simple turning or by milling tools.

1. Inserts for turning
2. Inserts for milling

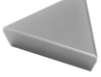

## Inserts for turning

	CODE	T	C.i.D.	In	a°	S
	TPMR 160308	3	9,52	16,5	11°	3,18
	TPMR 220408	3	12,7	22	11°	4,76
	TPMR 270616	3	15,88	27	11°	6,35
	TPUN 160308	3	9,52	16,5	11°	3,18
	TPUN 220412	3	12,7	22	11°	4,76
	TPUN 270616	3	15,88	27	11°	6,35
	TPUN 330603	3	19,05	33	11°	7,94

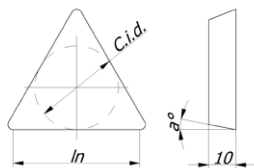

## Inserts for milling

	CODE	T	C.i.D.	d	S
	CNCQ 150604	4	15,88	6	6,35

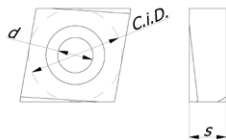

	CODE	T	L	In	a°	d	s
	SPCT 1504-AP-5A 4	4	15,88	12,4	11°	4,5	4,76

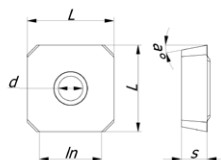

# Bar peeling Tools

Diamil is currently designing and manufacturing toolings and carbide spare parts for all the peeling machines. Whether the customer is interested in spare parts only or in a new project to improve machine performance we are able to fulfill its needs.

We design, manufacture and develop peeling head, both single and tandem insert's and antiwear parts to be used in the bar guiding system. The wide range of inserts in our peeling program and the wide experience developed in the past 20 years allows us to find the best solution for every machine and type of machining.

In order to facilitate data collection we created the following chart and relative drawings with the main dimensions needed to quote a tools and create a draft for an alternative solution.

Bar peeling Tools



Parameter	Description
L	Head Total Height
L1	Centering Gap
$\alpha$	Fixing Plug Angle
$\varnothing A$	Inner Diameter
$\varnothing B$	Centering Diameter
$\varnothing C$	Fixing Diameter
$\varnothing D$	External Diameter

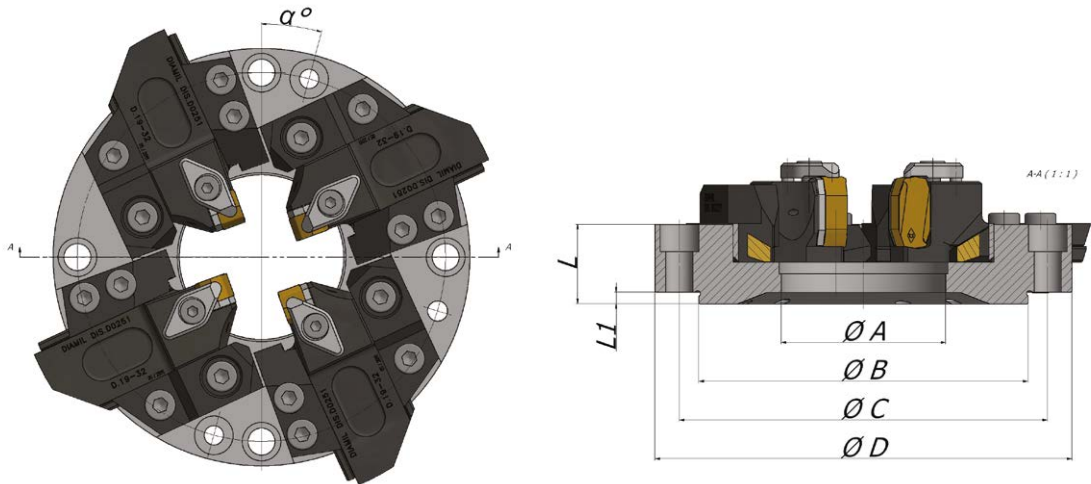

Parameter	Description
L	Total Length
H	Cutting Edge Height
H1	Total Height
A	Insert Seat Shoulder
B	Total Width

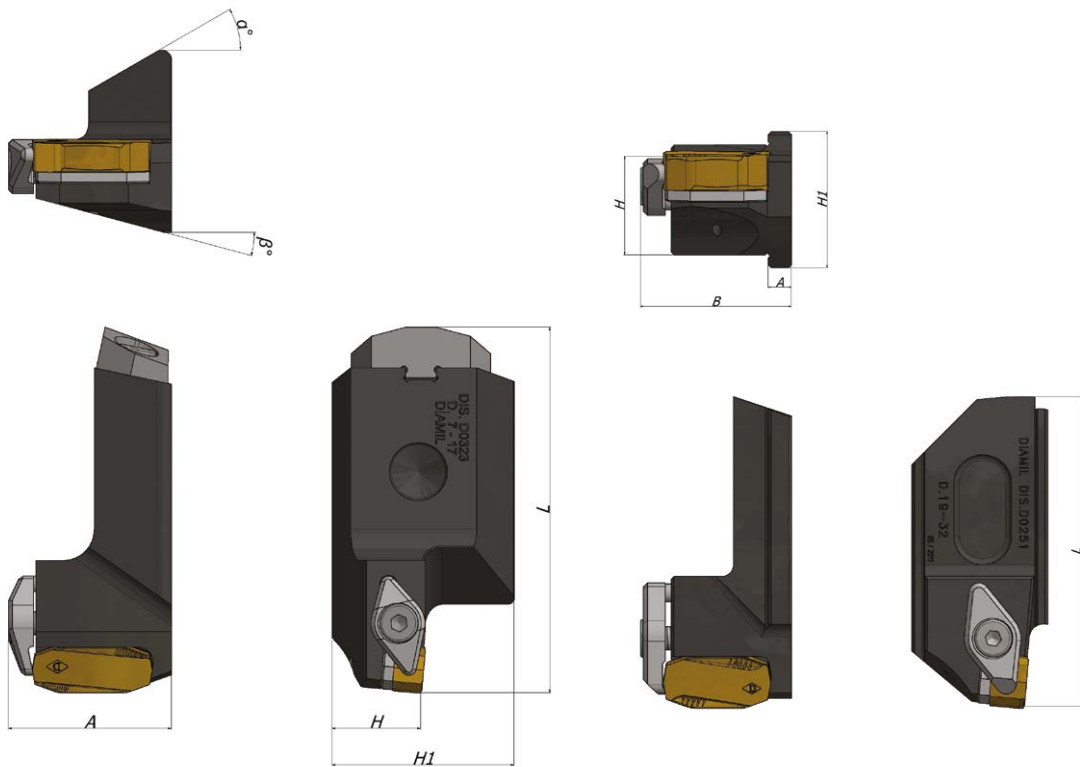

# The Company

Diamil, thanks to **over 30 years of experience** in the field, created a team able to **support customers in any technical issue** from machine settings to customized tools design for special machining.

With the aim of giving to **the customer the best service**, Diamil based its offer on a mixture of competence, **high quality products** and customized solutions.

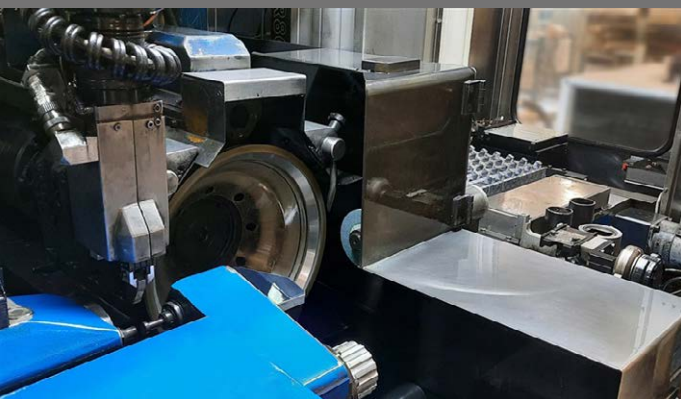

**DIAMIL**

tube & bar tools specialists

**OMCD GROUP**

## Customer Service Competence

Our skills at your disposal!  
We provide expertise and support to the customer being at his side, aware that service add an extra value to a high performance product.



The OMCD Group, headed by the Tedeschi family for two generations, is a multinational company made up of **10 brands active in the field of Hard Metal, sintered copper/tungsten and precious metals.**

Its centralized structure and **synergy between each brand** guarantees **control of the entire production process**, from the refining of minerals to the micro-finishing operations.

Technical **competence**, continuous **innovation** and focus on **customer satisfaction** are just some of the reasons why every day more and more companies rely on OMCD Group as their commercial business partner.



**DIAMIL**  
tube & bar tools specialists  
**OMCD GROUP**

**Diamil by Harditalia srl**  
Via Genova 9  
Oggiona con S.Stefano - 21040 (Va) Italia  
Tel. +39 0331 215007  
[harditalia@harditalia.com](mailto:harditalia@harditalia.com)  
[diamil.it](http://diamil.it) / [harditalia.com](http://harditalia.com)